

## Tehničke specifikacije

### Performance Parameters

Specification	EM231, 2AI×RTD	EM231, 4AI×RTD
Physical Features		
Dimensions(W×H×D)	71.2×80×62mm	71.2×80×62mm
Power Loss(dissipation)	1.7W	1.7W
Power Consumption		
From +5V(from I/O bus)	87mA	
From L+	60 mA	
L+ voltage range,class 2 or DC sensor supply	20.4 ~ 28.8V DC	
LED indicator	24 VDC Power Supply Good: ON = no fault, OFF = no power ; SF: ON=module fault, Blink=input signal error, OFF=normal;	
Analog Input Features		
Input type	Module ground reference RTD	
Input range	RTD type(select one per module): Pt-100Ω , 200Ω , 500Ω , 1000Ω(α =3850PPm , 3920PPM , 3850.55 PPM , 3916PPM , 3902PM) Pt-10000Ω(α=3850PPM) Cu-9.035Ω(α=4720PPM) Ni-10Ω , 120Ω , 1000Ω(α=6720PPM)	

	, 6178PPM) R-150Ω , 300Ω , 600Ω	
Number of analog input points	2 points	4 points
Isolation		
Field to Logic Field to 24V DC 24V DC to logic	500V AC 500V AC 500V AC	
Common mode input range (input channel to input channel)	120V AC	
Common mode rejection	>120dB@120V AC	
Input resolution		
Temperature Resistance	0.1°C/0.1°F 15 bits plus sign	
Measuring principle	Sigma-Delta	
Module update time for all channel	425ms	825ms
Wire length to sensor, maximum	100 m	
Wire loop resistance	20Ω, 2.7KΩ for Cu maximum	
Suppression of interference	85dB@ 50Hz/60Hz/400Hz	
Data word format	Resistance: -27648 to +27648	
Maximum sensor dissipation	1mW	
Input impedance	≥10MΩ	
Maximum input voltage	30 VDC (sensor), 5 VDC (source)	

Input filter attenuation	-3dB@ 3.6kHz
Basic error	0.1% FS(Voltage)
Repeatability	0.05% FS
24V DC supply voltage range	20.4 to 28.8 VDC

You can wire the RTD sensors directly to the EM231 RTD modules, or you can use extension wires. Please use shielded wires to acquire best noise immunity. If you use shielded wires, connect the shield to the ground on pin 1 to 4 of the signal connector. This ground is the same ground as is present on the power connector pin 3 to 7. If you do not use an RTD input channel, you should wire a resistor to the unused channel inputs in order to prevent errors from floating inputs from blocking error indications from valid channels.

Connect user power to the power connector pin 1 and 2. You must connect pin 3 to a nearby chassis ground (Figure 2).

You can wire the RTD module to the sensor in three ways (shown in Figure 3). The most accurate mode is 4 wire (see Figure 3). The least accurate mode is 2 wire, which is only recommended if errors due to wiring can be ignored in your application.

#### Figure 1 Connector Terminal Identification for RTD Modules Configuration

The EM231 RTD modules provide a convenient interface to connect CTS7-200 PLC to several different RTDs. It also allows the CTS7-200 PLC to measure three different resistance ranges. You must use DIP switches to select RTD type, wiring configuration, temperature scale, and burnout direction. Both RTDs connect to a module must be of the same type.

The configuration DIP switches are located on the right bottom of the module, as shown in Figure 4. For the DIP switch settings to take effect, you need to power cycle the PLC or the 24V power supply.

#### Selecting the RTD type

Select RTD type by setting DIP switch 1 to switch 8 to correspond to the RTD as shown in Table 1 and Table 2.

Table 1 Selecting the RTD Type

RTD type	SW1	SW2	SW3	SW4	SW5
100 Pt 0.003850(Default)	0	0	0	0	0
200Ω Pt 0.003850	0	0	0	0	1

500Ω Pt 0.003850	0	0	0	1	0
1000Ω Pt 0.003850	0	0	0	1	1
100Ω Pt 0.003920	0	0	1	0	0
200Ω Pt 0.003920	0	0	1	0	1
500Ω Pt 0.003920	0	0	1	1	0
1000Ω Pt 0.003920	0	0	1	1	1
100Ω Pt 0.00385055	0	1	0	0	0
200Ω Pt 0.00385055	0	1	0	0	1
500Ω Pt 0.00385055	0	1	0	1	0
1000Ω Pt 0.00385055	0	1	0	1	1
100Ω Pt 0.003916	0	1	1	0	0
200Ω Pt 0.003916	0	1	1	0	1
500Ω Pt 0.003916	0	1	1	1	0
1000Ω Pt 0.003916	0	1	1	1	1
100Ω Pt 0.00302	1	0	0	0	0
200Ω Pt 0.003902	1	0	0	0	1
500Ω Pt 0.003902	1	0	0	1	0
1000Ω Pt 0.003902	1	0	0	1	1
Reserved	1	0	1	0	0
100Ω Ni 0.00672	1	0	1	0	1
120Ω Ni 0.00672	1	0	1	1	0
1000Ω Ni 0.00672	1	0	1	1	1

100Ω Ni 0.006178	1	1	0	0	0
120Ω Ni 0.006178	1	1	0	0	1
1000Ω Ni 0.006178	1	1	0	1	0
10000Ω Pt 0.003850	1	1	0	1	1
10Ω Cu 0.004270	1	1	1	0	0
150Ω FS Resistance	1	1	1	0	1
300Ω FS Resistance	1	1	1	1	0
600Ω FS Resistance	1	1	1	1	1

Dimenzije

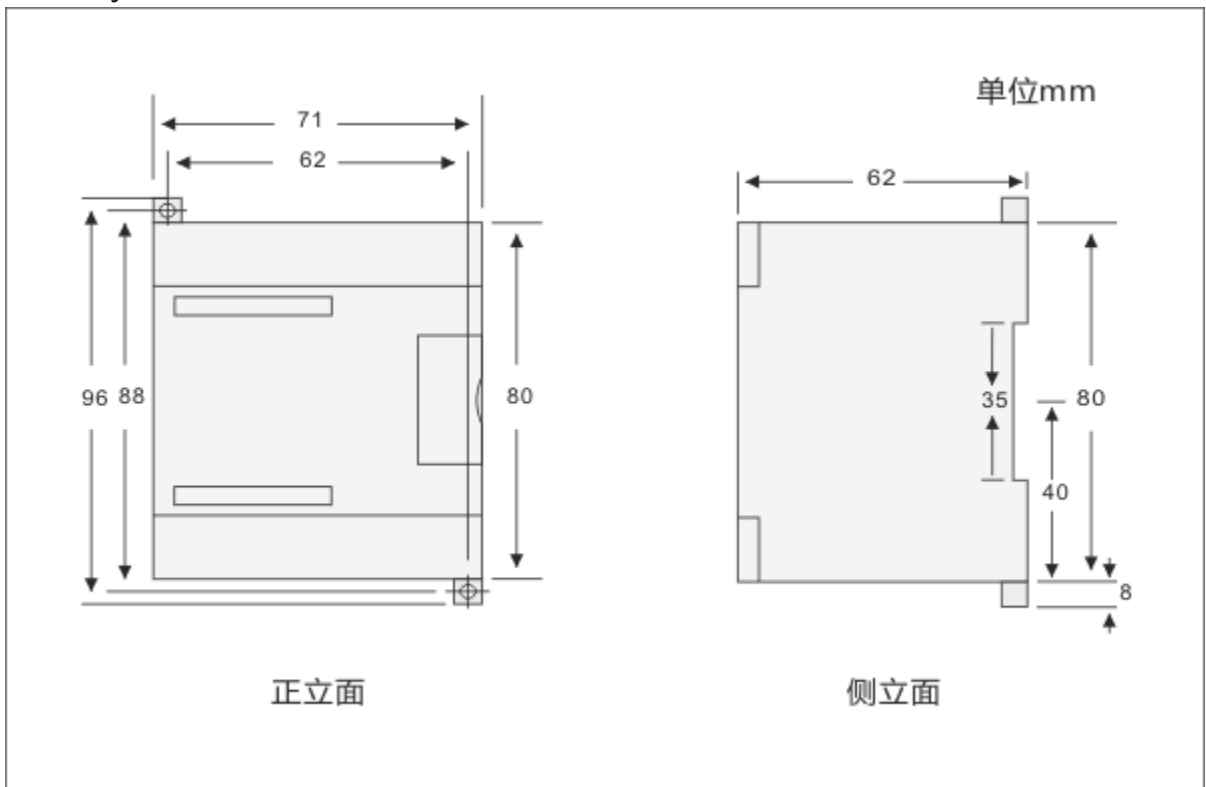

Šema spajanja

CTS7 231-7PB32 热电阻模块

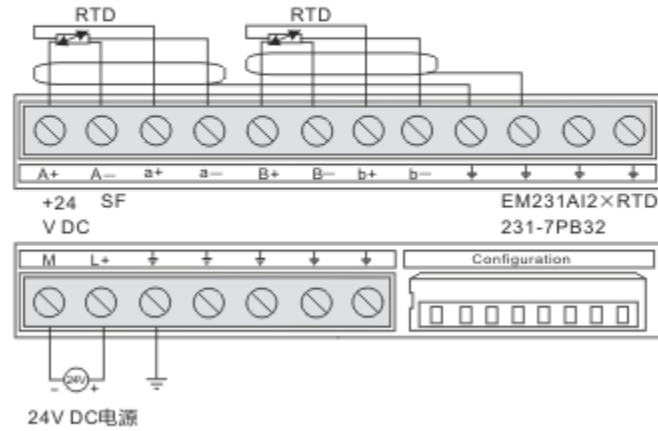

CTS7 231-7PC32 热电阻模块

